

3rd generation HDMI repeaters with audio extract/insert - Product Summary -

HSR-82



HSR-41



First generation HDMI products supported 165 MHz pixel rates; which allowed 1080p 60 Hz video with 8 bit/component color depth. Second generation HDMI products supported 225 equivalent pixel rates, allowing for 1080p 60 Hz video with more than 8 bits/pixel. Third generation HDMI products support 300 MHz (equivalent), allowing for 4K 24/30 Hz video.

Built with HDMI technology from Analog Devices, MDS OEM HDMI repeater modules for AV applications offer a unique set of features for audio applications. A separate product line is available for users needing 4th generation HDCP 2.2 support for 4K sources.

With MDS modules manufacturers can have solutions ready for markets with minimal development. Manufacturers can focus on the user experience and "front panel" and "rear panel" design and avoid the headaches of the high speed design and the complex software for HDMI processing.

Product Details

The following table summarizes the HDMI repeater products available from MDS. All inputs feature adaptive cable EQ that supports (typical, for good quality source and cable) 10m at the highest supported data rate.

The HDMI inputs and outputs support the mandatory video features found in the HDMI 1.4 specification, and the Deep Color (12 bits) at up to 1080p resolution. Color Gamut Metadata is supported to allow the use of xvYCC color spaces (HDMI 1.4 x.v.Color).

All use high quality Tyco HDMI connectors to ensure reliable connector operation over the life of the product.

Audio extract/insert

All MDS HDMI repeater products extract the audio (as four I²S lines along with a SPDIF line) for local processing. The audio decoder can then provide a downmixed stereo PCM signal for the HDMI transmitter.

Model	Inputs	Outputs	3D	OSD	Audio Loop	DSD	ARC	CEC
HSR-82	8	2 (common video)	Yes	Yes	Yes	No	Yes	Yes
HSR-41	4	1	Yes	Yes	Yes	No	Yes	Yes

Notes: ARC requires CEC. CEC not defined for more than one output.

Common design

The HSR-41 and HSR-82 are mechanically compatible with the 2nd generation (225 MHz) HSR-5 and HSR-8-3D products. The same connector signals are used, though there are

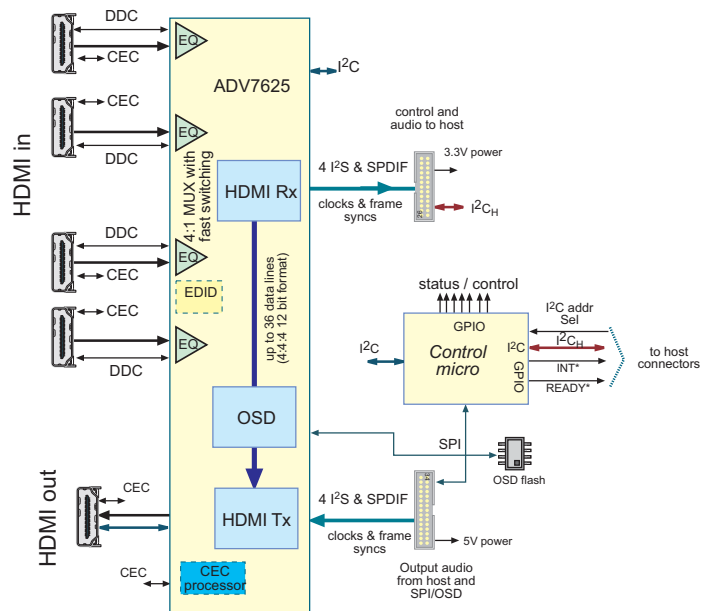

HSR-41 Block Diagram

slightly different operational characteristics due to the HDMI parts used.

The software API for the HSR-41 and HSR-82 are a superset of the 225 MHz products. This commonality in hardware and software allows system designs to easily incorporate any MDS HDMI repeater product.

Other products

MDS' HDMI experts are available to help create custom products as well as work with your engineering team to support your own product development.

MDS products include a selection of 2nd generation (225 MHz) HDMI repeater products for applications where the higher speeds are not needed.

MDS also offers large HDMI matrix cross-bars such as our HXBAR-88 and 1616 (8 in 8 out, and 16 in 16 out) any to any switcher/repeater with independent audio routing.

HDMI switcher/repeater modules

Flexible output control

An HDMI device with 2 outputs may not function well in the real world if it simply assumed the two connected HDMI sink devices support the same capability. For example, an HDMI source might need to route to an audio system and a projector. The projector might only support stereo PCM audio.

If the repeater blindly took the lowest common format among the connected sink devices, the audio system would always be fed 2 channel PCM data by the source instead of surround sound (compressed) data.

The HSR-82, with its dual outputs, can be told to assign input audio formats from different sink device capabilities to determine what the HDMI source should send (as determined when the source device reads the EDID).

OSD

The HSR-41 and HSR-82 can overlay a basic "ASCII text" OSD on 2D video. MDS provides two factory default high level OSD functions, one to display arbitrary text at up to 9 places on the screen (typically for showing input source, status, etc.) and the other for a volume control type bar indicator.



Custom OSD example

More complex OSDs with icons and menus can be created by directly using the features of the ADV7625 BLIMP software. MDS offers consulting services to assist with creation of custom host cre-

ated OSDs.

Four input, single output repeater

MDS offers a four input, one output switcher/repeater modules, the HSR-41.

The HSR-41 can loop audio from input to output; for AV Receiver applications the general mode of operation is that the decoder would be fed the (Dolby/DTS) encoded input and supply a stereo (PCM) downmix for the sink device.

Mechanically the HSR-41 can mount into the same set of holes as the HSR-82, simplifying chassis designs when two different configurations may be desired.

The HSR-41 supports pass through of the mandatory 3D formats defined in the HDMI 1.4a specification. The ARC feature is supported but requires a full CEC implementation of the

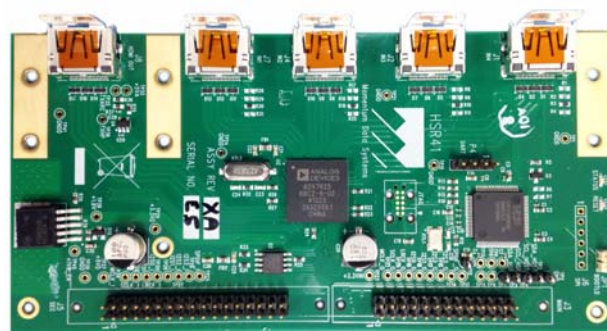

HSR-41 HDMI switcher/repeater

Audio System logical device as defined in the HDMI 1.4a specification.

Eight input, two output matrix repeater

Many AV applications require sending video to one location and audio to another; alternately the need may be to send video to two different locations, for example a main screen in the home theater and a second TV in the kitchen area. The HSR-82 provides two outputs to remove the need for an external HDMI splitter/repeater.

Note that CEC and ARC are only supported on the primary output, the CEC specification does not support multi-output repeaters.

Since the HSR-82 has audio loop through capability it can be used as a standalone HDMI matrix switcher repeater. Only a power supply and a small microprocessor for a front panel and/or external control interface are needed to make a complete system.

Developing with MDS HDMI modules

MDS offers an evaluation kit that provide everything needed to evaluate the modules and start code development on your host processor.

The kit include the module (mounted to a base), interconnect cables, power supply, a (generic) host side API library, and a microprocessor based demonstration program to simplify experimentation.

Users integrating with MDS Digital Audio products should purchase the appropriate audio development platform as it includes more comprehensive system level examples.

Host connectors

A 26 pin IDC (.1") connector carries primary 3.3V power, the I²C control signals, and the audio signals received by the card.

Note that the audio data may be invalid due to the source creating bad data or things like cable disconnects. Users of the audio data should check status to mute during recog-

PRELIMINARY - SUBJECT TO CHANGE

HDMI switcher/repeater modules

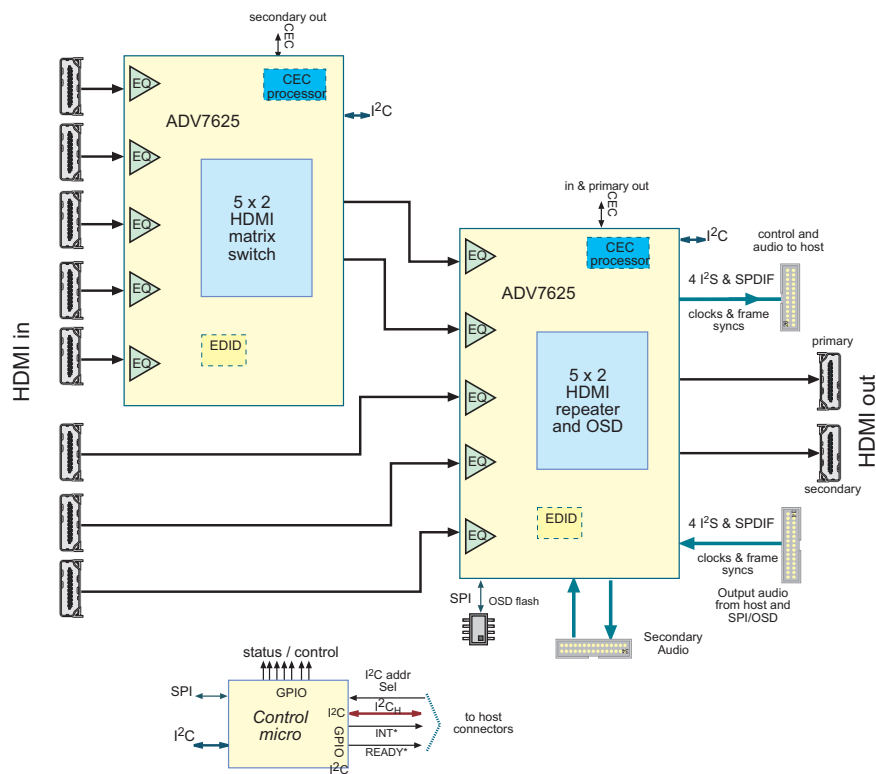

HSR-82 Block Diagram

nized invalid data periods and be prepared to handle audio clock discontinuities.

MDS Alpha messaging control protocol

All products uses the same I²C based messaging protocol used on other MDS OEM products. Users of those products will find the HDMI modules easy to control; users new to the MDS alpha messaging protocol can start with supplied C++ based examples that can be recompiled to run on typical embedded 32 bit microcontrollers.

Evaluation kit

To gain experience with integrating MDS HDMI products into your system design, MDS offers an evaluation kit that includes the selected HDMI repeater board and the adapter board shown on the next page.

Using this board and the provided software the HSR can be controlled and configured without the need to have your own host application code running yet.

Pass through connectors allow connecting to your audio subsystem but still use the MDS provided GUI software for control and status monitoring. Alternately the EVM board can be setup for loopback of received HDMI audio to the output.

An audio DAC is connected to the primary I2S input line to allow playback of 2 channel stereo PCM without need to

connect external devices. Likewise a SPDIF in and out allows for easy experimentation before connecting into a more complex system.

Board integration

The boards require 3.3 and 5V power, if CEC is used these supplies must be provided when the system is in standby (depending on the model, standby mode power draw is less than 350 mW).

In addition to the I2S related signals, connection to I2C clock/data, and the (board to host) interrupt line are needed. The board's reset input should only be released once the supplies are stable and the host is ready to start interacting with the board. For full details the relevant hardware manual should be consulted.

MDS HDMI testing of a final unit

MDS must be supplied with a final unit to run a range of mandatory HDMI tests to ensure conformance with the HDMI licensing rules. Customers with their own HDMI license can do their own family product self certifications.

Two levels of testing are possible, a basic test for cases where CEC is not being used, and a combined basic plus CEC test for units that will use CEC (use of ARC requires CEC). Typical test periods run from 1 to 3 days, unless problems are found, which is unlikely in the basic tests but possible in the CEC test as the host software must process and respond to a range of possible CEC messages.

PRELIMINARY - SUBJECT TO CHANGE

HDMI switcher/repeater modules

Ordering information

Minimum order quantity of standard OEM boards is 50 pieces. Please contact MDS' OEM sales manager for details.

HSR-82: 8 input, dual output HDMI switcher/repeater.

- HDMI 1.4a mandatory 3D formats
- Up to "4K" pixel rates at 24/30 Hz
- Up to 12 bit Deep Color
- Color Gamut Metadata (xvYCC color space) supported
- Audio extraction/injection (I2S standard) and loop through
- CEC switch and Audio System device support
- ARC (primary output)
- OSD (built-in & custom)
- MDS custom HDCP code to minimize blackouts when sinks change state

HSR-41: 4 input HDMI switcher/repeater.

- HDMI 1.4a mandatory 3D formats
- Up to "4K" pixel rates at 24/30 Hz
- Up to 12 bit Deep Color
- Color Gamut Metadata (xvYCC color space) supported
- Audio extraction/injection (I2S standard) and loop through
- CEC switch and Audio System device support
- ARC (primary output)
- OSD (built-in & custom)

Note that the actual allowed input format is determined by the sink device(s) connected to the unit, the above descriptions define the maximum available capability.

Related products

#-EVM-KIT: Add this suffix to the above for the developer/eval kit

- Selected board
- IDC cables
- Eval adapter board with USB port to I²C feature to allow control from a PC 'terminal'
- Control API documentation
- Example code
- Connector, power, and mechanical information
- Power supply (110/220 universal input brick)

HTEST-BASIC: HDMI product family self certification test

HTEST-CEC: For HDMI product using CEC (or ARC), verification of proper CEC handling

Licensing

These products use licensed technologies and are only available for sale to authorized audio / video companies. Please contact MDS for more information.

Trademarks:

Dolby is trademark of Dolby Laboratories, Inc., DTS is a trademark of Digital Theater Systems, Inc. HDMI, the HDMI logo and High-Definition Multimedia Interface are trademarks or registered trademarks of HDMI Licensing LLC. HDCP is a trademark of Digital Content Protection, LLC. x.v.Color is a trademark of Sony DAE and DAE-6D are trademarks of MDS.

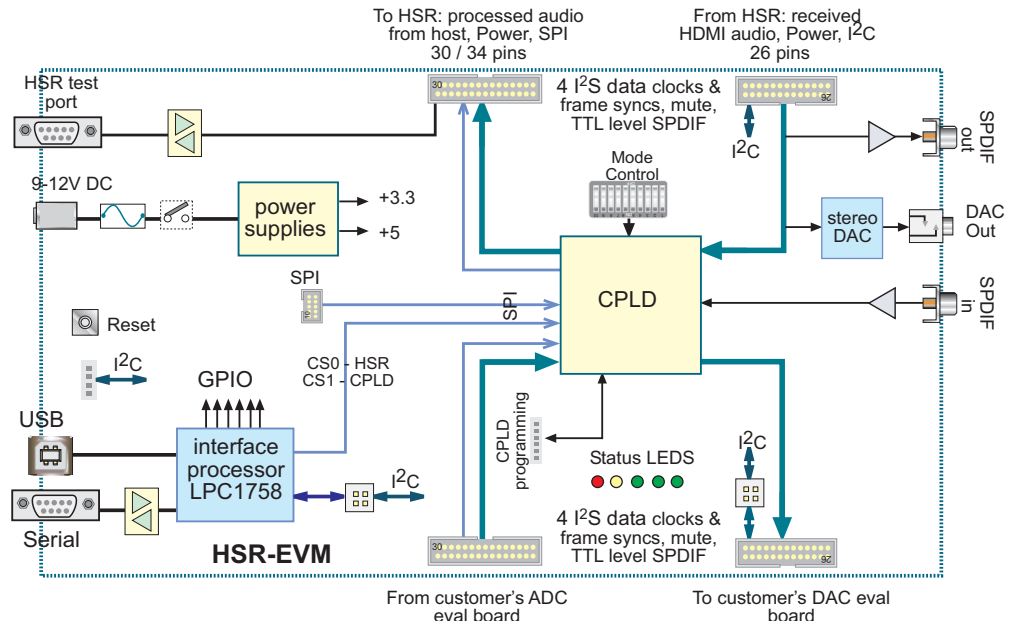

Eval kit adapter board